

RFK-0620 Flake Ice Machine

Models

- RFK0620A RFK0620W



Model RFK-0620A
Flake Ice Machine
on D-420 Bin

Standard Features

- Up to 760 lbs. (345 kgs) daily flake ice production.
- High load maintenance free bearing for enhanced reliability
- Service updates facilitate installation and make cleaning easier.
- Flake ice is perfect for food display, salad bars, and cold therapy/healthcare
- Ice forms around object without bruising and holds objects in place without tipping/spilling.
- Heavy duty stainless steel cabinet resists corrosion.



Specifications

BTU per hour:

Air: 5,200 (average)
Water: 2,250 (average)

Compressor:

Nominal rating: 1 HP

Refrigerant: R452A

Operating Limits:

- Ambient Temperature Range: 50°-110°F (10°-43°C)
- Water Temperature Range 37°-90°F (3°-32°C)
- Water Pressure Ice Maker
Water In
Min. 14 psi (96.5 kPa)
Max. 80 psi (551.6 kPa)
- Condenser Inlet Water In: (water-cooled only)
Min. 20 psi (137.9 kPa)
Max. 150 psi (1034.2 kPa)
Water Condenser not for sea water applications.

Ice Machine Electric

230/50/1

Minimum circuit ampacity:

7.7 amps (air)
7.1 amps (water)

Maximum fuse size:

15 amps
HACR-type circuit breakers
can be used in place of fuses.

Ave Power Consumption:

1,050 W

Ice Shape

Flake ice is small hard bits of ice ideally suited for presentation applications.

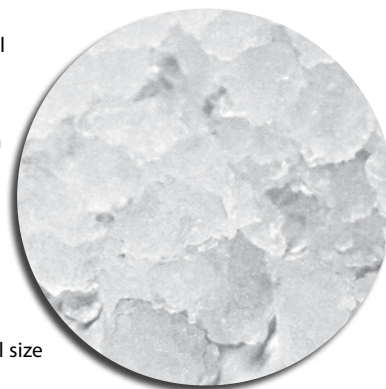

Ice shown actual size





RFK-0620 Flake Ice Machine

RFK-0620 on D-420 Storage Bin

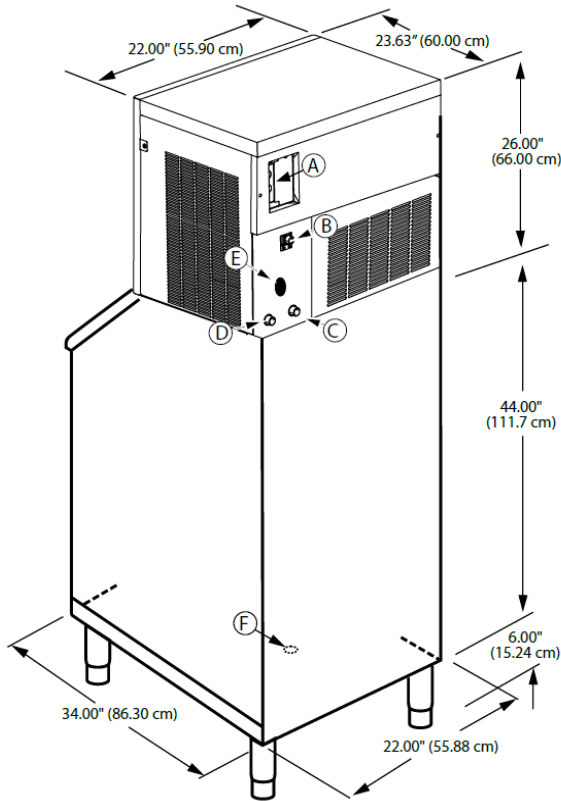

- (A) Electrical Entrance (2) Options
- (B) 3/8" F.P.T. Condenser Inlet (water-cooled only)
- (C) 1/2" M.P.T. Condenser Drain (water-cooled only)
- (D) 1/2" M.P.T. Ice Making Water Drain
- (E) 3/8" F.P.T. Ice Making Water Inlet
- (F) 3/4" Bin Drain

Installation Note -
 Minimum installation clearance:
 Top/sides: 8" (20.32 cm),
 Back: 5" (12.70 cm).

Space-Saving Designs



RFK-0620 on D-420

Height	76.00" 193.00 cm
Width	22.00" 55.90 cm
Depth	34.00" 86.36 cm
Bin Storage	310 lbs. 140.7 kgs

Height includes adjustable bin legs
 6.00" to 7.00", (15.24 to 17.78 cm)
 set at 6.00" (15.24 cm).

Accessories

K-00472 30" D Style Bin Adapter
 for fitting to D-570 ice bin.

Air Flow Overhead View

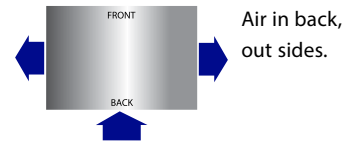

Model	Ice Shape	Ice Production 24 Hours Based on Air/Water Temp				Power kWh/100 lbs @ 90°Air/70°F Water	Potable Water Usage (100 lbs./ 45.4 kgs of Ice)	Condenser Water at 90/70°F 32° Air/21° C Water
		70° Air/50°F Water 21° Air/10° C Water	90° Air/70°F Water 32° Air/21° C Water					
RFK0620A	Flake	760 lbs.	345 kgs	540 lbs.	245 kgs	4.74	12 gal./45.4 L	N/A
RFK0620W	Flake	744 lbs.	337 kgs	586 lbs.	266 kgs	3.98	12 gal./45.4 L	70 gal./265 L

Welbilt reserves the right to make changes to the design or specifications without prior notice.

www.manitowocice.com

Welbilt Deutschland GmbH
 Auf der Weih 11
 D - 35745 Herbborn,
 Germany
 Tel.: +49 27 72 58 050
welbilt.com.de

Welbilt Iberia, S.A.U
 Textil, 6 - Pol.Ind. La Ferreria
 - 08110 Montcada i Reixac
 Barcelona, Spain
 Tel.: +34 902 20 10 69
welbilt.com.es

Welbilt UK
 Ashbourne House, The Guildway,
 Old Portsmouth Rd, Guildford
 GU3 1LR, United Kingdom
 Tel.: +44 1483 464900
www.welbilt.uk

